

V-5400 / V-5403 EVOLUTION MINI SOFT-CLOSE
V-5100 / V-5103 EVOLUTION

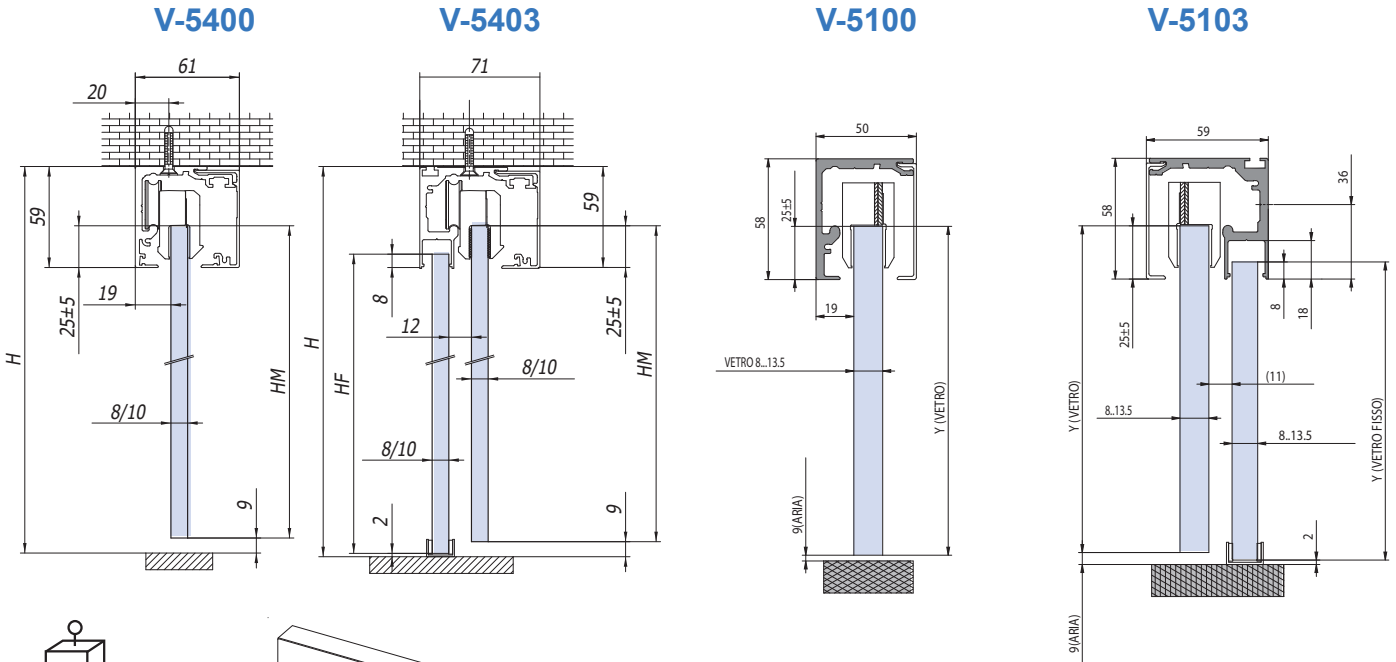

120 Kg

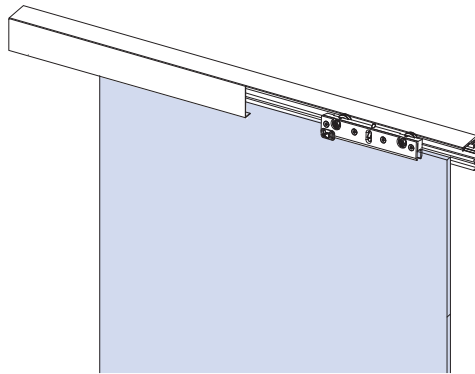
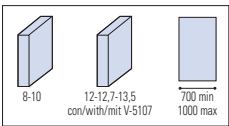

ACCESSORI - ACCESSORIES - ZUBEHÖR

V-5102

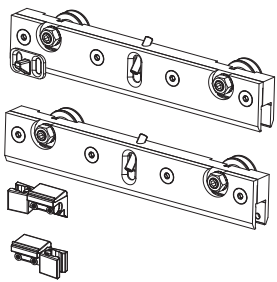

120 Kg

- x 2 carrelli
- x 2 *clamp carriers*
- x 2 Laufwagen
- x 2 stopper sicurezza
- x 2 *safety stoppers*
- x 2 Sicherheitsstopper

V-5401

- x 2 Tappi laterali per V-5400
- x 2 *Endcaps for V-5400*
- x 2 Endkappen für V-5400

V-5411

- x 2 Tappi laterali per V-5403
- x 2 *Endcaps for V-5403*
- x 2 Endkappen für V-5403

V-5101

- x 2 Tappi laterali per V-5100
- x 2 *Endcaps for V-5100*
- x 2 Endkappen für V-5100

V-5111

- x 2 Tappi laterali per V-5103
- x 2 *Endcaps for V-5103*
- x 2 Endkappen für V-5103

V-5406-120
V-5406
V-5406-70 C



- x 2 ammortizzatori soft-close
- x 2 *soft-close mechanism*
- x 2 Soft-close Selbststeinzug

Soft-close x V-5400/V-5403

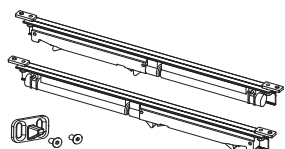

- x 1 attivatore soft-close
- x 1 *soft-close activator*
- x 1 Soft-close Mitnehmer

disponibili | available | verfügbar
V-5406 -120 **V-5406** **V5406-70 C**

120 Kg

80 Kg

70 Kg

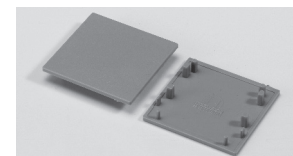

V-5400 / V-5403 EVOLUTION MINI SOFT-CLOSE V-5100 / V-5103 EVOLUTION

1

Posizionare la barra a muro, metterla a bolla e fissarla con dei tasselli (tasselli non inclusi, usare tasselli adeguati al tipo di carico e muratura)

Installation of track profile, profile must be fixed aligned.

Please use suitable fixing material according to foundation

Laufschiene an der Wand positionieren, mit Wasserwaage in die Waagrechte bringen und fixieren (Schrauben nicht inbegriffen, dem Gewicht und der Mauerbeschaffenheit entsprechende Schrauben und Dübeln verwenden)

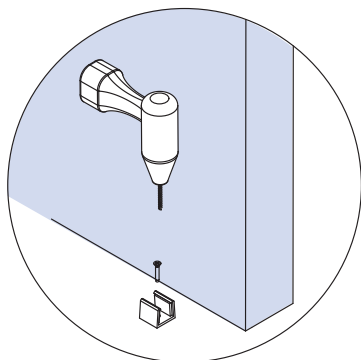

2

Posizionare la guida a terra e fissarla con un tassello

Installation of floor guide

Bodenführung positionieren und mit Schraube befestigen

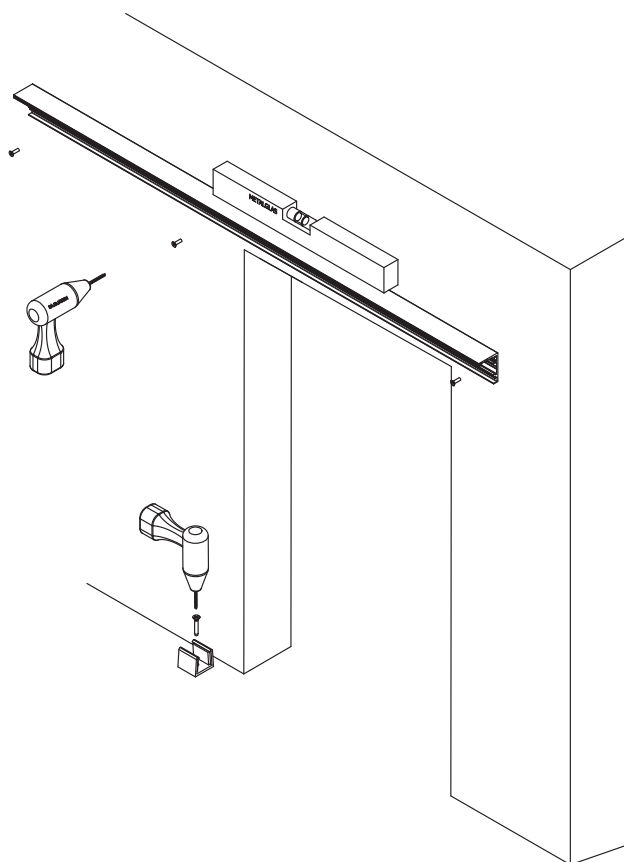

3

In caso di montaggio di profilo con sede per vetro fisso V-5403 / V-5103, montare il vetro nell'apposita sede come da figura.

Installation of the fixed side panel, insert from ahead

Montage von vorne, das Glas von unten einführen, wie auf der Zeichnung dargestellt

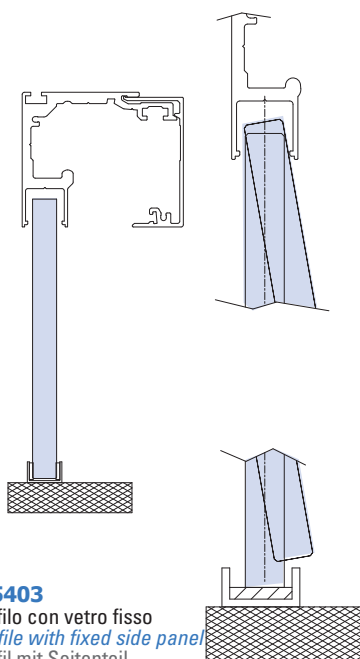

V-5403

Profilo con vetro fisso

Profile with fixed side panel

Profil mit Seitenteil

V-5400 / V-5403 EVOLUTION MINI SOFT-CLOSE
V-5100 / V-5103 EVOLUTION

4

Montare i carrelli sull'anta scorrevole N.B. MONTARE A TERRA
Installation of clamp carriers, assemble on the ground
 Laufwagen auf der Glasschiebetür montieren zu beachten: am Boden montieren!

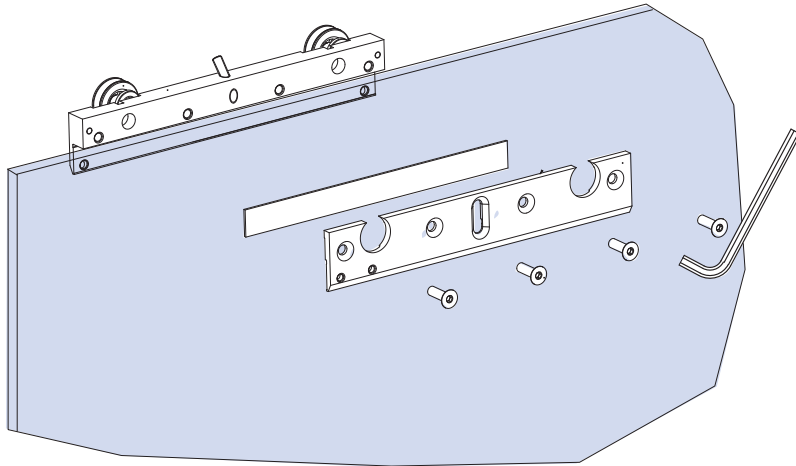

M6 x 20
 4 mm
 18 Nm

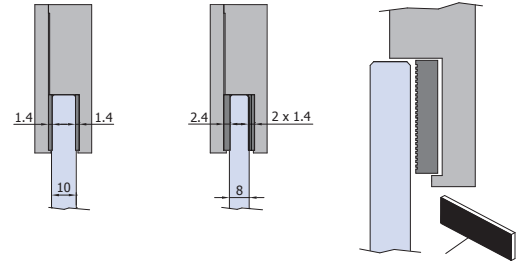

Lato ruvido
Rough side
 Grobteil

La parte ruvida della guarnizione deve essere a contatto con il vetro per garantire una presa ottimale
The gasket rough side has to be in contact with the glass to guarantee an optimal grip.
 Dichtung Grobteil muss mit dem Glas Kontakt haben um einen optimalen Anschluss zu haben.

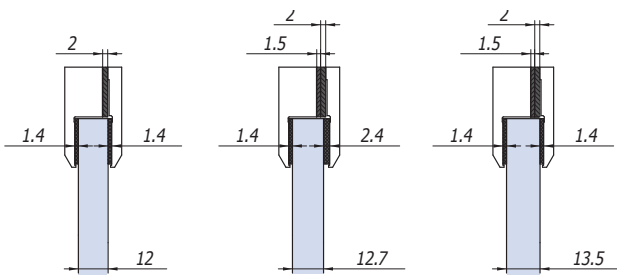

2 X
2 X

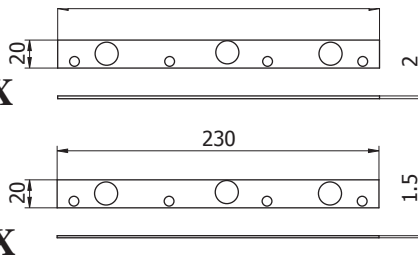

V-5107 Optional
 Kit per spessori vetro
 mm. 12 - 12,7 - 13,5 mm (per 2 pinze)
Kit spacers for glass thickness
 12 - 12,7 - 13,5 mm (for 2 clamps)
 Distanzscheiben entsprechend der Glasdicke verwenden

5 Azzerare le ruote e l'antiscangio dei carrelli (per regolare le ruote vedi pag. 6)
Line up the roller clamp wheels
 Schrauben der Laufräder und des Aushebeschutz bis zum Anschlag drehen

RUOTA PORTANTE
CARRYNG WHEEL
 LAUFRAD

ANTISCANGIO
ANTI JUMP
 AUSHEBESCHUTZ

RUOTA PORTANTE
CARRYNG WHEEL
 LAUFRAD

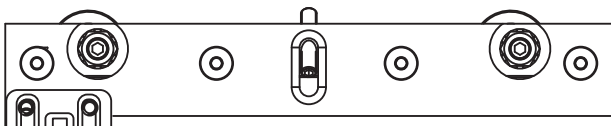

x 1 Attivatore Soft-close (per V-5400 / V-5403)
x 1 Soft-close activator (for V-5400 / V-5403)
 x 1 Soft-close Mitnehmer (für V-5400 / V-5403)

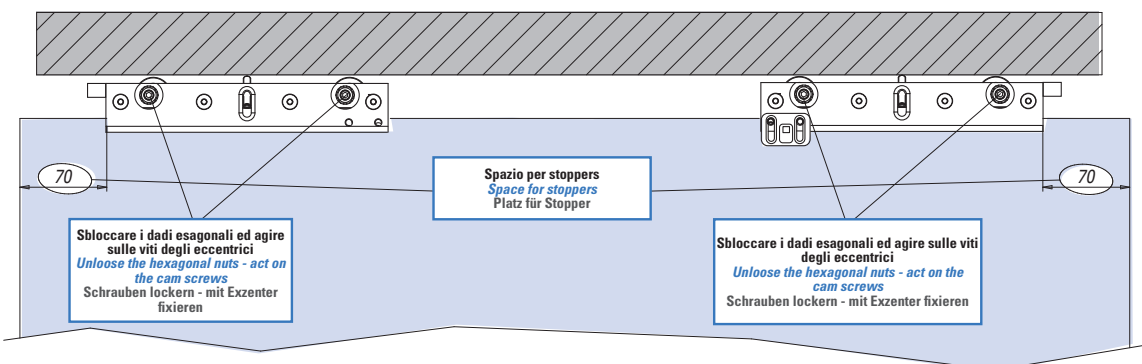

Sbloccare i dadi esagonali ed agire sulle viti degli eccentrici
Unloose the hexagonal nuts - act on the cam screws
 Schrauben lockern - mit Exzenter fixieren

Spazio per stoppers
Space for stoppers
 Platz für Stopper

Sbloccare i dadi esagonali ed agire sulle viti degli eccentrici
Unloose the hexagonal nuts - act on the cam screws
 Schrauben lockern - mit Exzenter fixieren

V-5400 / V-5403 EVOLUTION MINI SOFT-CLOSE

6

Inserire gli ammortizzatori e gli stoppers nell'apposita sede del binario
Installation of soft-close mechanism and safety stoppers into the track rail
Selbsteinzug und Stopper in die Laufschiene einführen



CON/WITH/MIT
OPTIONAL
SOFT-CLOSE V-5406

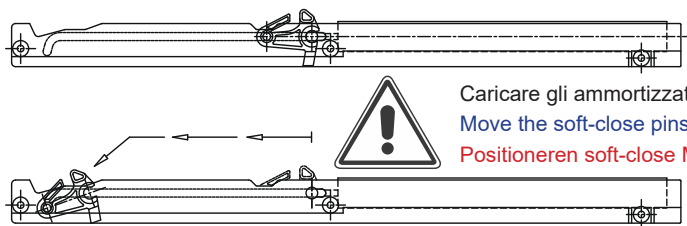
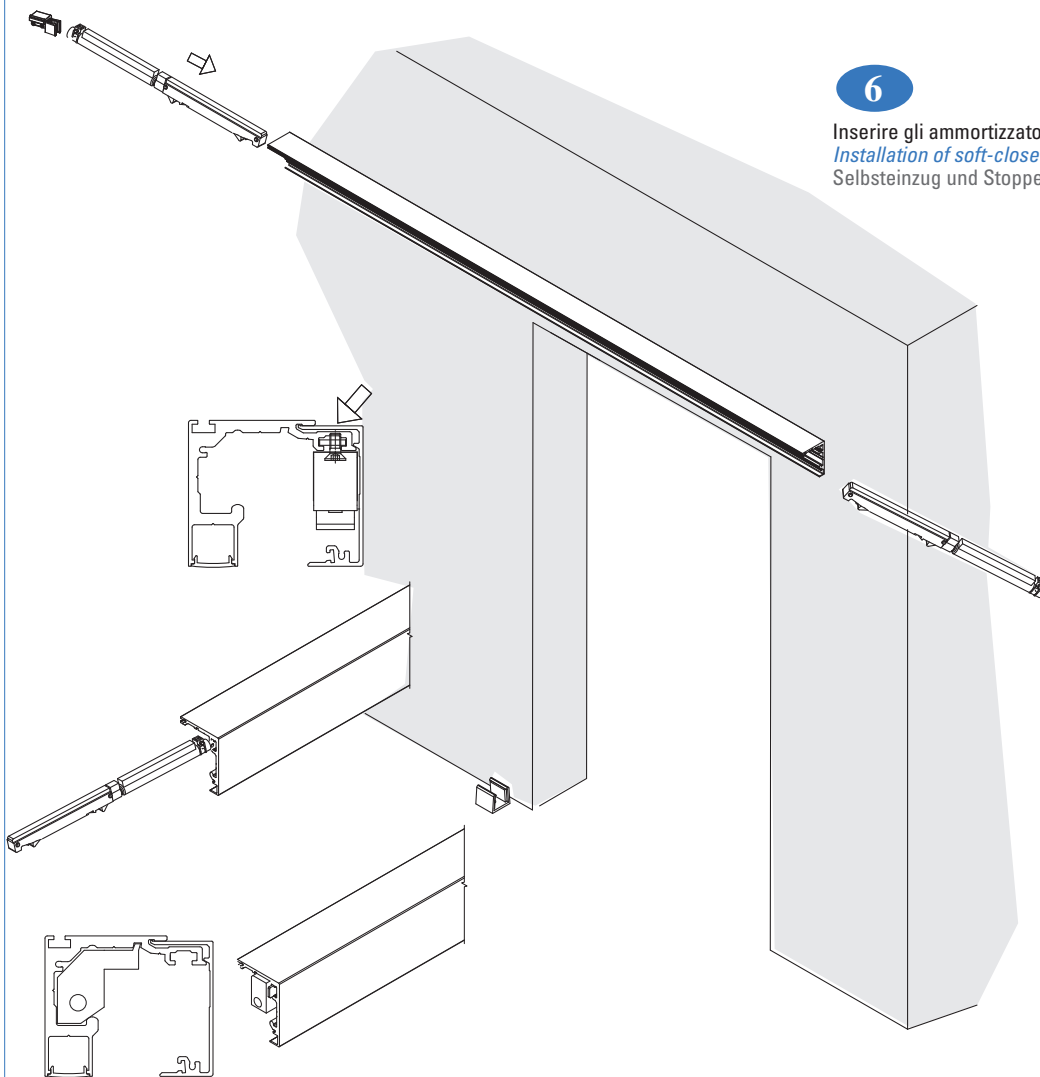
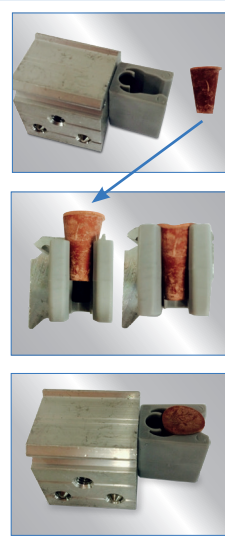

Caricare gli ammortizzatori
Move the soft-close pins in loaded position
Positionieren soft-close Mitnehmer in der gespannten Position

ATTENZIONE !!!
Seguire lo schema sotto per inserire in maniera corretta gli ammortizzatori e gli stoppers nel binario
ATTENTION !!!
please follow the drawing for the correct installation of soft-close and stoppers
ACHTUNG!!!
Selbsteinzug und Stopper nach Anleitung richtig einführen

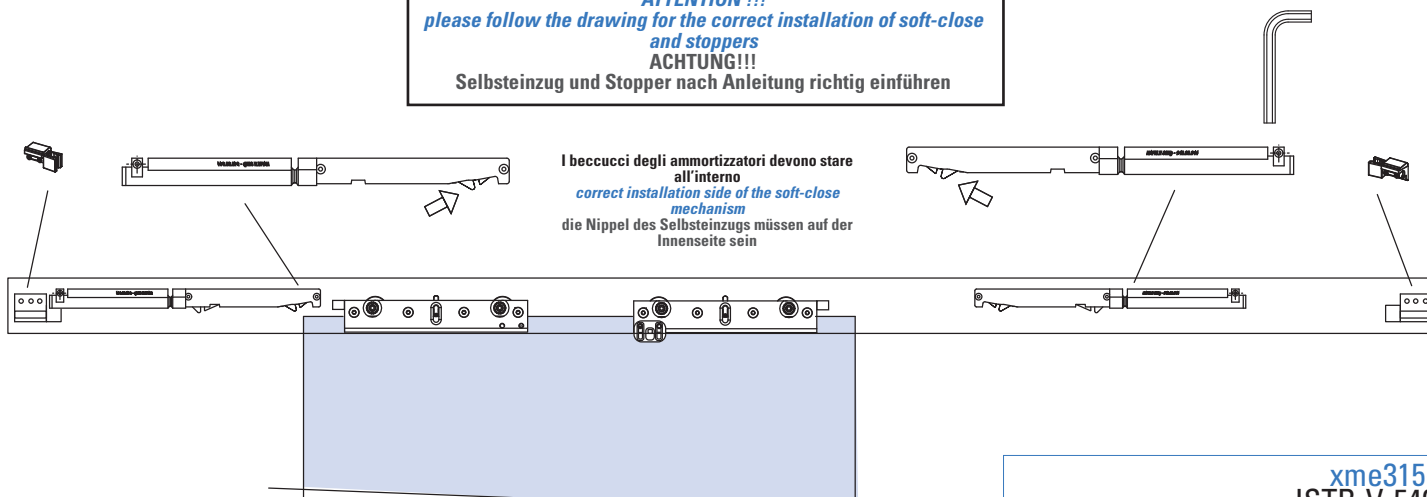

I beccucci degli ammortizzatori devono stare all'interno
correct installation side of the soft-close mechanism
die Nippel des Selbsteinzugs müssen auf der Innenseite sein

V-5400 / V-5403 EVOLUTION MINI SOFT-CLOSE
V-5100 / V-5103 EVOLUTION

7

Montare l'anta sul binario
Fitting of sliding door on the track rail
 Glasschiebetür auf Schiene einhängen

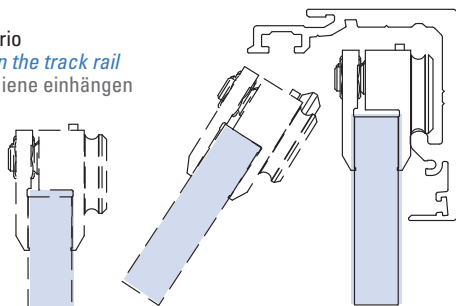

Assicurarsi che le ruote appoggino sulla sede corretta del binario
Check wheels are in the correct position in the rail
 sicherstellen, dass die Räder auf der Laufschiene richtig sitzen

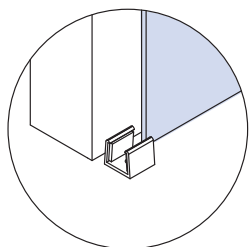

Infilare l'anta nella guida a terra
Position sliding door with the floor guide
 Schiebetür in die Bodenführung positionieren

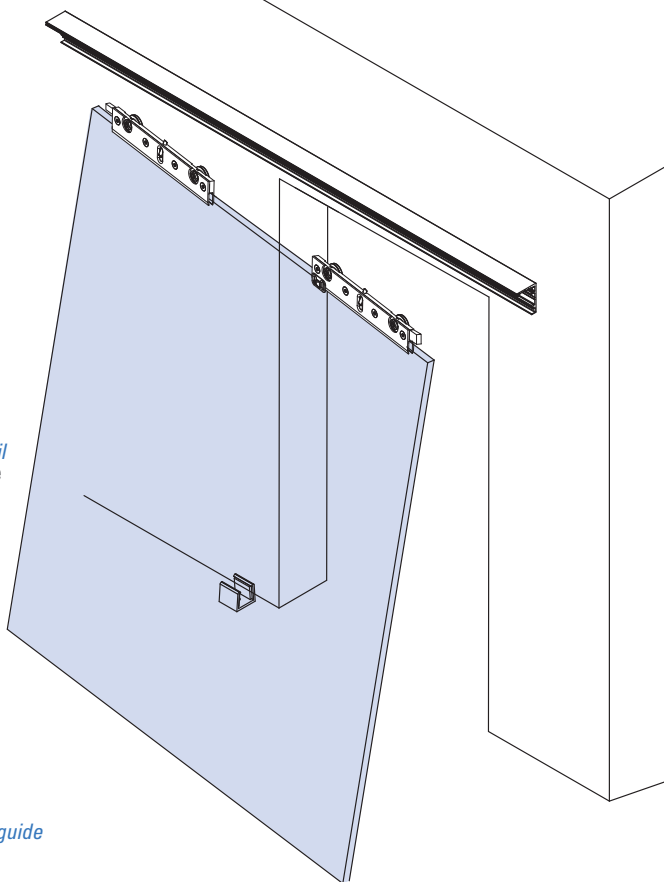

RUOTA PORTANTE
CARRING WHEEL
 LAUFRAD

ANTISGANCIO
ANTI JUMP
 AUSHEBESCHUTZ

RUOTA PORTANTE
CARRING WHEEL
 LAUFRAD

18 Nm

18 Nm

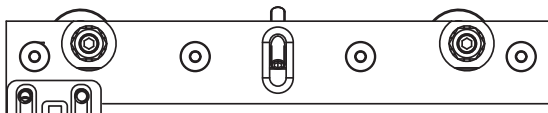

AGIRE SULLE VITI DEGLI ECCENTRICI - BLOCCARE DADI
ACT ON THE CAM SCREWS
 SCHRAUBEN LOCKERN - MIT EXZENTER FIXIEREN

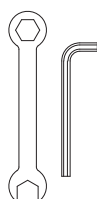

8

Regolare i carrelli e l'antisgancio (per regolazione ruote e antisgancio vedi pag 6) e successivamente assicurarsi che la porta non possa uscire dalla guida
Assemble and adjust roller clamps (adjustment wheels, see page 6)
 Laufwagen und Aushebeschutz einstellen
 (für die Regelung der Räder und Aushebeschutz siehe Seite 6) und sicherstellen, dass die Türe nicht aus der Führung herausfällt



Assicurarsi che il morsetto di trascinamento azioni il beccuccio dell'ammortizzatore, in caso contrario regolare l'altezza del morsetto (apposite viti frontali)
Adjust the height of the clamp follower according soft-close mechanism
 Sicherstellen, dass der Mitnehmer den Nippel des Selbsteinzugs betätigt, ansonsten die Höhe des Klemmlaufwagens variieren (mit den entsprechenden Schrauben)

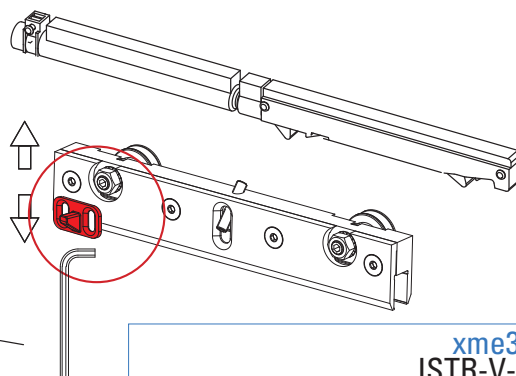

V-5400 / V-5403 EVOLUTION MINI SOFT-CLOSE
V-5100 / V-5103 EVOLUTION

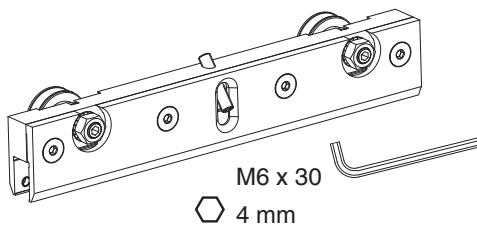
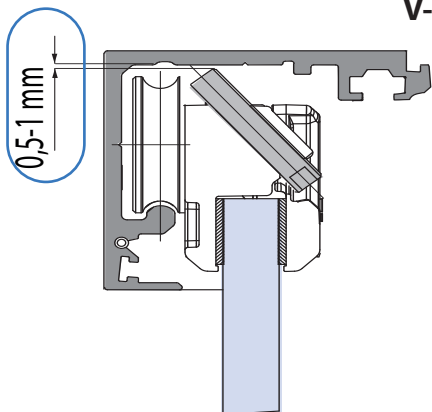

9

Regolare l'antisgancio
Adjust the antijump
 Aushebeschutz einstellen

SOFT-CLOSE V-5406
x V-5400 / V-5403

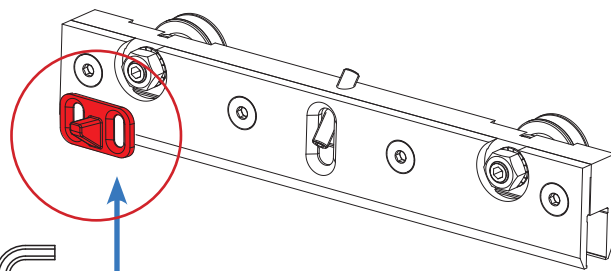
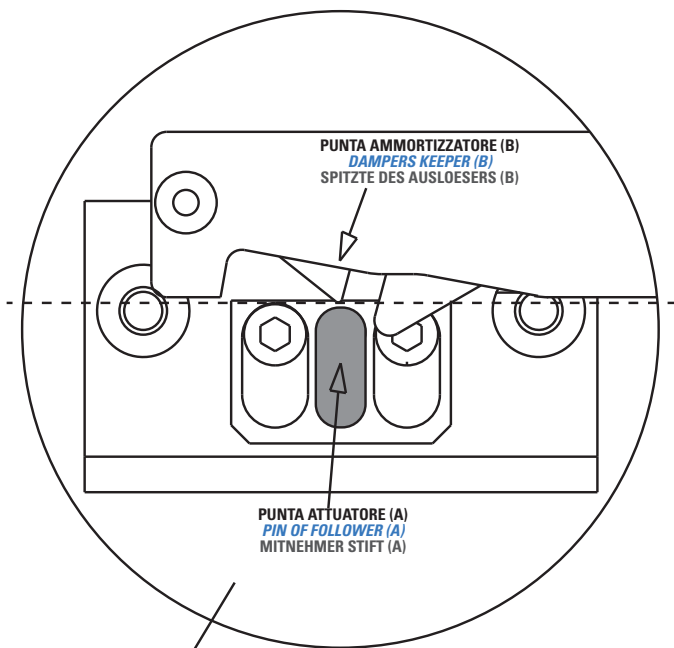

PUNTA ATTUATORE (A)
 PIN OF FOLLOWER (A)
 MITNEHMER STIFT (A)

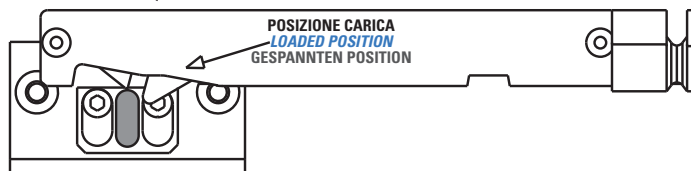

Con l'ammortizzatore in posizione di carica, il perno (A) deve essere posizionato a sfiorare la punta dell'ammortizzatore (B). Se il perno è inserito troppo nelle due punte dell'ammortizzatore, in fase di sgancio potrebbe causare rumore

Adjustment of carrying and The pin of follower A must be adjusted so that when the damper loaded ist, the pin A must be just slightly under the dampers keeper B

Mitnehmer Stift A ist in der Höhe verstellbar. In der gespannten Position muss der Stift A so positioniert werden, dass er mit der Spitze des Auslösers B

System di regolazione ruote e antisgancio carrelli

Adjustment of carrying and antijump wheels

Einstellung der Räder und des Aushebeschutz am Laufwagen

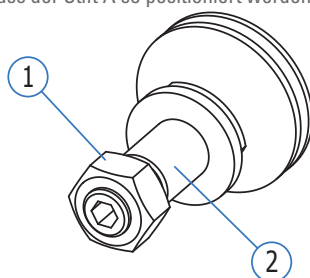
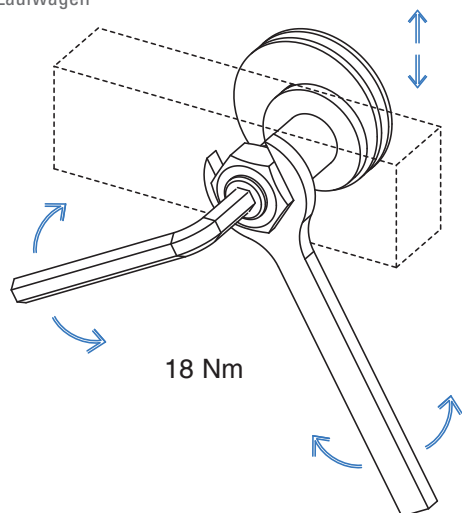

LEGENDA:

1- dado per bloccaggio

2- perno eccentrico

1- locking nut

2- cam pin

BESCHREIBUNG:

1 - Schraube zum Festziehen

2 - Stift des Exzenters

NB: USARE CONTEMPORANEAMENTE LE CHIAVI

1- agire sul dado per sbloccare

2- agire sul perno per regolazione

3- agire sul dado per bloccare

USE THE SPANNERS SIMULTANEOUSLY

1-height adjustment, the height can be adjusted ± 4 mm

ZU BEACHTEN: BEIDE SCHLÜSSEL GLEICHZEITIG

VERWENDEN

1 - Schraube lockern

2 - Regulierung des Stiftes

3 - Schraube festziehen

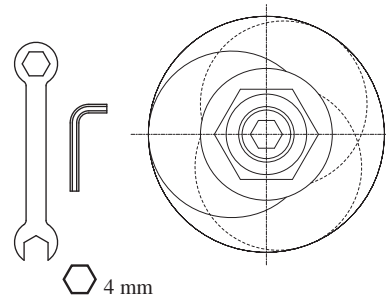

V-5400 / V-5403 EVOLUTION MINI SOFT-CLOSE
V-5100 / V-5103 EVOLUTION

V-5403 / V-5103

USARE GRANO M6 x 16
 SCREW M6 x 16
 GEWINDESTIFTEN M6 x 16

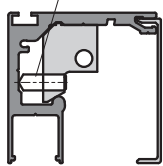

V-5400 / V-5100

USARE GRANO M6 x 10
 SCREW M6 x 10
 GEWINDESTIFTEN M6 x 10

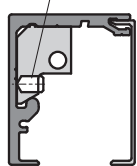

10

Regolare la posizione dell'ammortizzatore e dello stopper in base alla larghezza del vano
Adjust the position of the soft-close mechanism according to the opening width
 Selbsteinzug und Stopper nach Lichterbreite einstellen

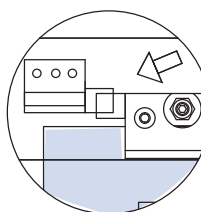
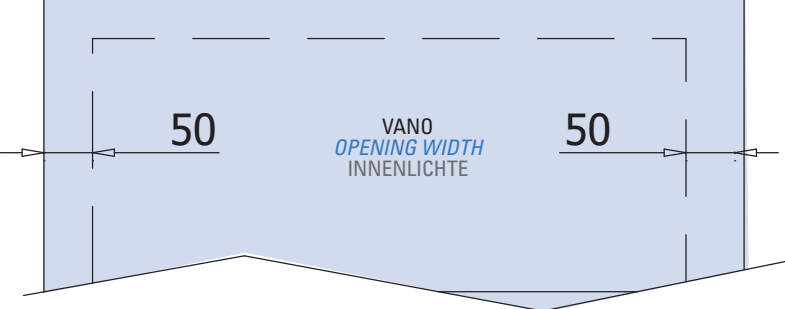
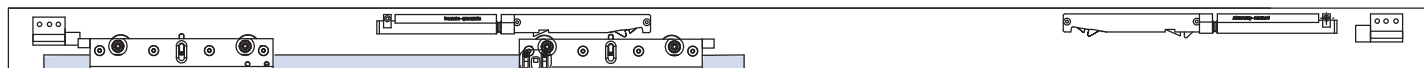
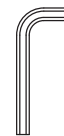

NB:
 Lo stopper deve fermare l'anta prima della fine della corsa dell'ammortizzatore, montarlo in modo che l'anta in posizione di apertura o di chiusura appoggi sullo stopper
Adjust the safety stoppers with the clamp carriers, in opening and closing situation
ZU BEACHTEN:
 der Stopper muss die Bewegung der Tür beenden nachdem der Selbsteinzug betätigt wurde, so montieren, dass die offene als auch die geschlossene Tür den Stopper berührt

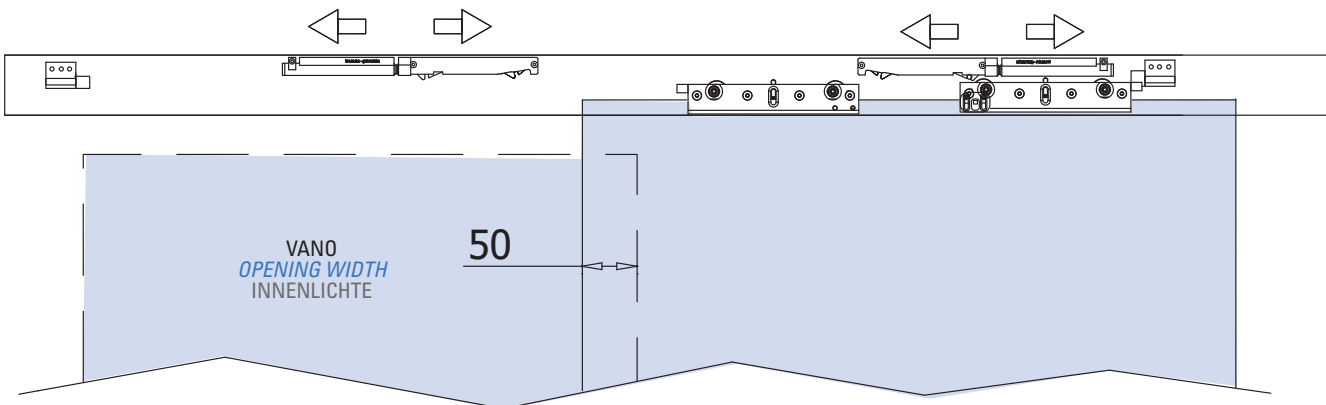

11

Fissare la veletta con gli appositi grani M4
Assemble cover profile with delivered grub screws M4
 Abdeckung mit den entsprechenden Gewindestiften befestigen M4

NB: Attenzione al verso della veletta
ATTENTION: cover profile this side up
ZU BEACHTEN: Beachten Sie die richtige Seite der Abdeckung



Utilizzare fori esistenti su trafilato
Use preholes already existent
 bestehende Bohrungen verwenden

12

Fissare i tappi finali, infine controllare il funzionamento dell'anta
Installation of endcaps
 Endkappen befestigen, Türlauf kontrollieren

V-5400 / V-5403 EVOLUTION MINI SOFT-CLOSE V-5100 / V-5103 EVOLUTION

x V-5100 / V-5103

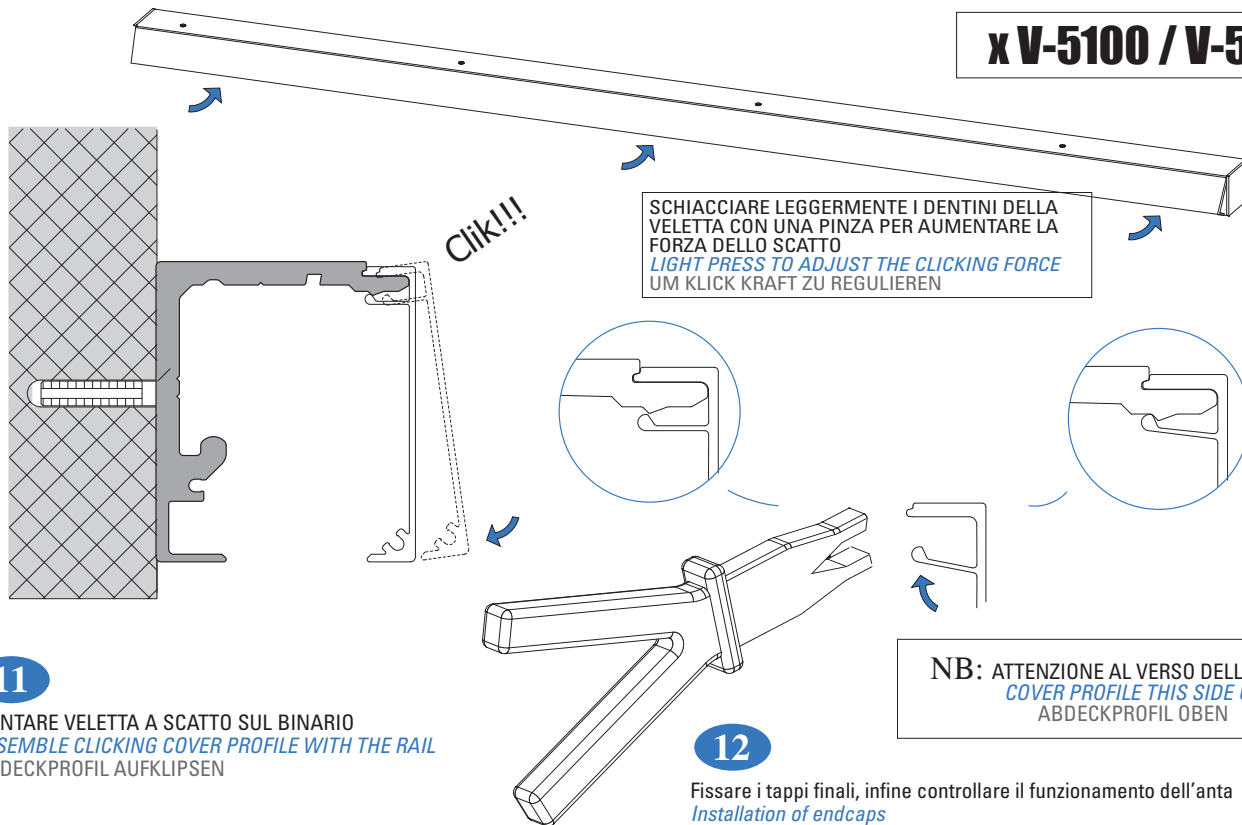

11

MONTARE VELETTA A SCATTO SUL BINARIO
ASSEMBLE CLICKING COVER PROFILE WITH THE RAIL
ABDECKPROFIL AUFKLIPISEN

12

Fissare i tappi finali, infine controllare il funzionamento dell'anta
Installation of endcaps
Endkappen befestigen, Türlauf kontrollieren

13

In caso di fissaggio a vetro forare il binario in corrispondenza dei fori nel vetro, successivamente avvitare il binario con gli appositi profili V-6006
With glass installation, it is necessary to drill track rail and use profiles V-6006
Bei Montage auf Glas muss der Laufschiene, gebohrt werden. Den Laufschiene am Glas mit den dafür vorgesehenen Profile V-6006 fixieren

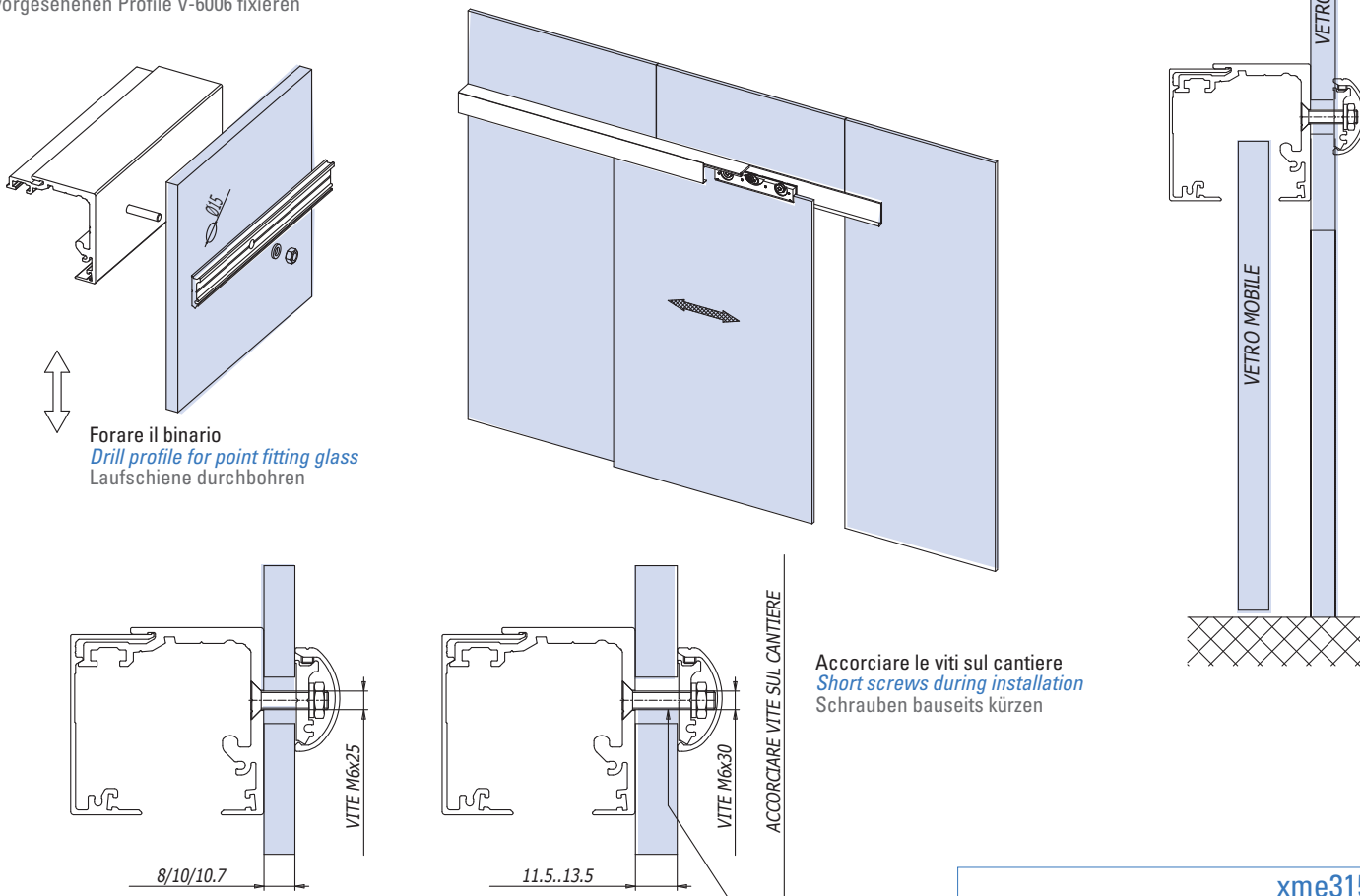

Accorciare le viti sul cantiere
Short screws during installation
Schrauben bauseits kürzen